

"R10" PIPE RUPTURE VALVE

General Information & Application Data

GENERAL DESCRIPTION

The design is proven with twenty years of acceptance in the elevator industry. To date over 100,000 units have been sold.

In the event of a failure in the cylinder supply line or when the down speed exceeds the field adjustable limit, the "R10" activates, bringing the car to a smooth and safe stop. The deceleration rate is comfortable (less than 1g) to passengers. For safety reasons the deceleration rate is a non-adjustable built-in feature of the "R10".

The "R10" offers an inline or right angle design, whichever best simplifies piping for **new** installations or modernization. The available sizes are for 3/4 to 3 inch pipe. The standard couplings are either N.P.T. threads or Victaulic fittings. A combination of N.P.T. threads and Victaulic can be accommodated.



OPTIONS

• LOWERING SPEED

With this option, once the "R10" is actuated the car will not come to a complete stop, but will continue down to the bottom floor at a rate which is field adjustable.

• PILOT PORT

This option is for dual cylinder systems using two "R10's". Connecting the pilot ports of each valve ensures that both will close almost simultaneously, regardless where the rupture occurs.

• NORMALLY CLOSED SWITCH (N.C.S.)

The "R10" can be fitted with an electrical switch with both opening and closing contacts. The N.C.S. is rated for 230V @ 6A.

APPLICATION DATA

For proper sizing of the "R10" refer to figure 1. Ensure that the tripping flow rate (GPM x 1.25) is within the range for a given valve.

figure 1

PIPE RUPTURE VALVE "R10"	TRIPPING FLOW RATE (GPM)	MAX. PRESSURE (PSI)
.75 INCHES	2 - 26	1400
1 INCH	27-45	1400
1.5 INCHES	46-110	1400
2 INCHES	111-208	1200
2.5 INCHES	209-318	1000
3 INCHES	319-546	800



Electro-Mech. Industries

2420 Hamilton Rd., Arlington Heights, IL 60005
Phone (847) 593-4900 Fax (847) 593-1394

SPEC.: B7400-A
DATE: FEB 98

Manufactured by:



"R10" PIPE RUPTURE VALVE

INSTALLATION AND ADJUSTMENT

Turning the closing flow adjustment clockwise (decreasing the "h" dim.), the valve closes with increased oil flow. Refer to fig. 2 for approximate closing flows for various "h" dimensions.

The lowering speed option prevents the "R10" from closing fully providing a slow lowering speed. By turning the lowering speed adjustment clockwise the lowering speed is increased.

Pilot Port is used for dual cylinder systems using two "R10's", connect the pilot ports together using 1/4" pipe.

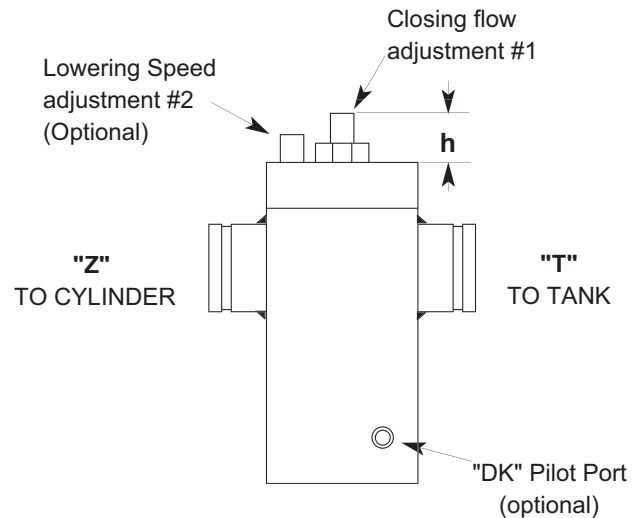

INSTALLATION

- Connect "Z" side of "R10" to Cylinder
- Connect "T" side of "R10" to Supply Line

ADJUSTMENTS (with rated load)

- Set closing flow adjustment #1 (dim. "h") to the approximate height refer to fig. 2
- Run car down at full speed
- Adjust closing flow (adjustment #1) to activate valve at full speed
- Turn closing flow adjustment clockwise per fig. 3 to obtain final setting
- Run car up under normal operation
- Verify closing flow by further opening down valve or increasing load to achieve over speed condition
- Verify that the valve will not trip at full speed with rated load during a full down run

CAUTION: In case the R10 is set incorrectly, be prepared to stop the car by other means before it enters the pit.

Note: For dual Cylinder applications perform adjustments to both valves.

For every clockwise turn of adjustment #1 the closing flow will increase per the following chart:

R10	GPM
3/4"	+4.7
1"	+7.8
1 1/2"	+9.9
2"	+14
2 1/2"	+22
3"	+33

Fig. 3

"h" Dimensions (Inches)

"R10" SIZE	CLOSING FLOW (GPM)													
	5	10	25	50	75	100	120	160	200	250	300	350	400	546
3/4"	1.05	0.93	0.7											
1"		1.1	0.85	0.6										
1 1/2"			1.05	0.8	0.65	0.5								
2"				1.1	0.95	0.85	0.75	0.62	0.42					
2 1/2"						1.05	1	0.9	0.75	0.6	0.42			
3"									1.05	0.96	0.87	0.75	0.68	0.4

Fig. 2



Electro-Mech. Industries

2420 Hamilton Rd., Arlington Heights, IL 60005
Phone (847) 593-4900 Fax (847) 593-1394

SPEC.: 7402-A
DATE: Jan. 96

Manufactured by:



"R10" PIPE RUPTURE VALVE

Dimensional Drawings

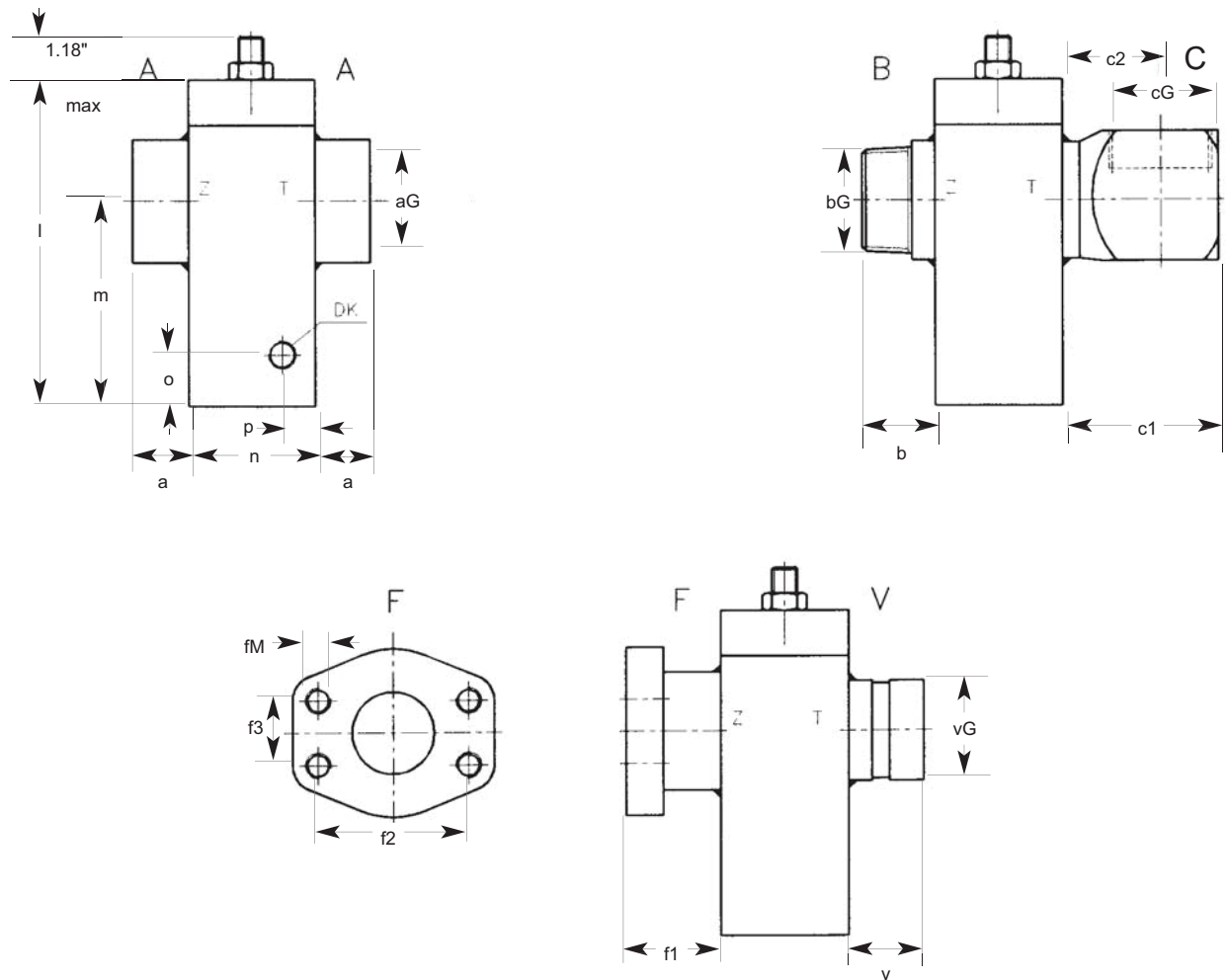

R10	A		B		C			F (SAE)					V		l	m	n	o	p	wt. (lbs)
	aG NPT	a a	bG NPT	b	cG NPT	c1	c2	DN	fM	f1	f2	f3	vG	V						
0.75	0.75	0.71	0.75	1.26	0.75	2.24	1.3						1.5	1.5	4.13	2.44	1.97	0.59	0.47	3.75
1	1	0.83	1	1.26	1	2.24	1.3						1.32	1.25	4.13	2.44	1.97	0.59	0.47	4
1.5	1.5	1.02	1.5	1.38	1.5	2.83	1.42	1.5	M12	1.73	2.76	1.41	1.9	1.4	5.94	3.7	2.36	0.94	0.59	5.75
2	2	1.1	2	1.5	2	3.27	1.77	2	M12	1.77	3.06	1.69	2.38	1.5	6.73	4.25	3.15	0.79	0.71	14
2.5	2.5	1.18	2.5	1.77	2.5	4.06	2.16	2.52	M12	1.97	3.5	2	2.88	1.75	7.72	4.76	3.94	0.98	0.87	26.8
3	3	1.39	3	1.77	3	4.72	2.56	2.99	M16	1.97	4.19	2.44	3	1.8	9.65	5.87	4.72	0.98	0.87	46.3



Electro-Mech. Industries

2420 Hamilton Rd., Arlington Heights, IL 60005
Phone (847) 593-4900 Fax (847) 593-1394

SPEC.: B7401-A
DATE: JAN. 95

Manufactured by:

